

# Type CGZ Crossgard Clutch

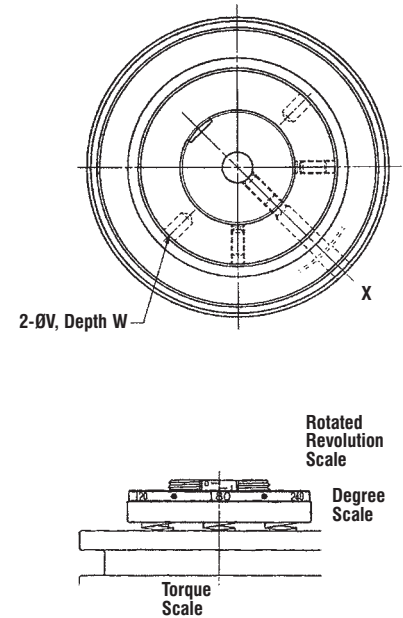

*Provides total disengagement in event of overload.  
Suitable for mounting gears, cams sprockets and timing belt pulleys*

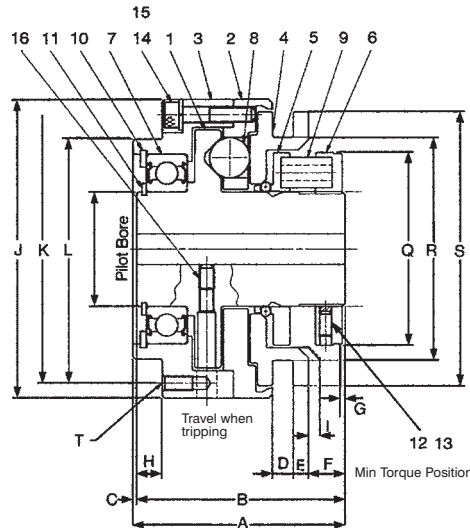

- 1 Hub
- 2 Centre Flange
- 3 Driven Flange Plate
- 4 Plate
- 5 Ball Cage
- 6 Adjustable Nut
- 7 Bearing (Z Type)
- 8 Steel Ball
- 9 Coil Spring
- 10 Snap Ring
- 11 Snap Ring
- 12 Set Screw
- 13 Lock Plug
- 14 Hex-Head Bolt
- 15 Spring Washer
- 16 Set Screw

For Selection of Crossgard CGZ Clutches refer to page 14.

Model	Setting Torque Range Nm	Max Running Speed RPM	Colour of Spring x Number	Pilot Bore mm	Max Bore mm	*Weight kg	Inertia kgm <sup>2</sup> (x10 <sup>-4</sup> )
CGZ20 L	2.4 - 8.3	1800	Yellow x 3	8	20	2.57	1.09
CGZ20 M	4.1 - 15.7		Blue x 3				
CGZ20 H	8.2 - 31.4		Blue x 6				
CGZ30 L	6 - 20	1800	Yellow x 4	12	30	4.17	2.78
CGZ30 M	20 - 52		Red x 4				
CGZ30 H	39 - 108		Red x 8				
CGZ40 L	26 - 93	1800	Blue x 5	17	40	8.71	9.60
CGZ40 M	44 - 127		Red x 5				
CGZ40 H	88 - 245		Red x 10				
CGZ50 L	63 - 157	1800	Red x 5	22	50	13.7	21.2
CGZ50 M	128 - 304		Red x 10				
CGZ50 H	245 - 450		Green x 10				

\*Weight and inertia values for clutches with max. bore.

Dimensions in mm.

Model	A	B	C	D	E	F	G	H	I Travel when tripping	J	K PCD	L h7	N	Q	R	S	T Screw			V	W	SIZE
																	No.	Size x length				
CGZ20	74	73	1	8	6	13.5	0.8	11	4.1	96	86	72	24.5	58	70	88	4	M5x10		5	10	M5x10
CGZ30	83.5	82	1.5	8	6	14.5	1.1	11.5	4.7	118	106	87	27.5	76	88	108	4	M6x12		6	10	M6x10
CGZ40	101	100	1	9	8	20	1.1	14	5.9	152	139	114	32.5	104	119	141	6	M6x12		8	14	M8x10
CGZ50	114.5	112	2.5	10	9	20.2	1.2	16	7	178	162	133	37	114	138	166	6	M8x16		9	14	M8x10

Type CGZ clutches totally disengage on overload, and will not re-engage drive without external axial force being applied to the pressure plate when the clutch is correctly aligned. The clutch must be stationary when re-engaged, otherwise the clutch may be damaged.

The CGZ clutch can be used as a mechanical engage/disengage clutch, but whilst the clutch can be dis-engaged at full speed by applying an axial force to the pressure plate, it can only be engaged whilst stationary. These clutches are designed for use on horizontal shafts, but may be applied to vertical shaft applications providing the driven flange plate is uppermost.